

BORAL ROOF TILES
Build something great™



AUGUST 2014

YOUR GUIDE TO ROOF TILES

HELPING YOU CHOOSE
THE BEST ROOF TILES
FOR YOUR NEW HOME

CONTENTS

Introduction	3
Why choose roof tiles	4
Types of roof tiles	6
How to choose a roof tile	8
Roof structure	13
Roof styles	13
Construction planning	14
Living energy-wise	15
Frequently asked questions	18
Roofing terms	19

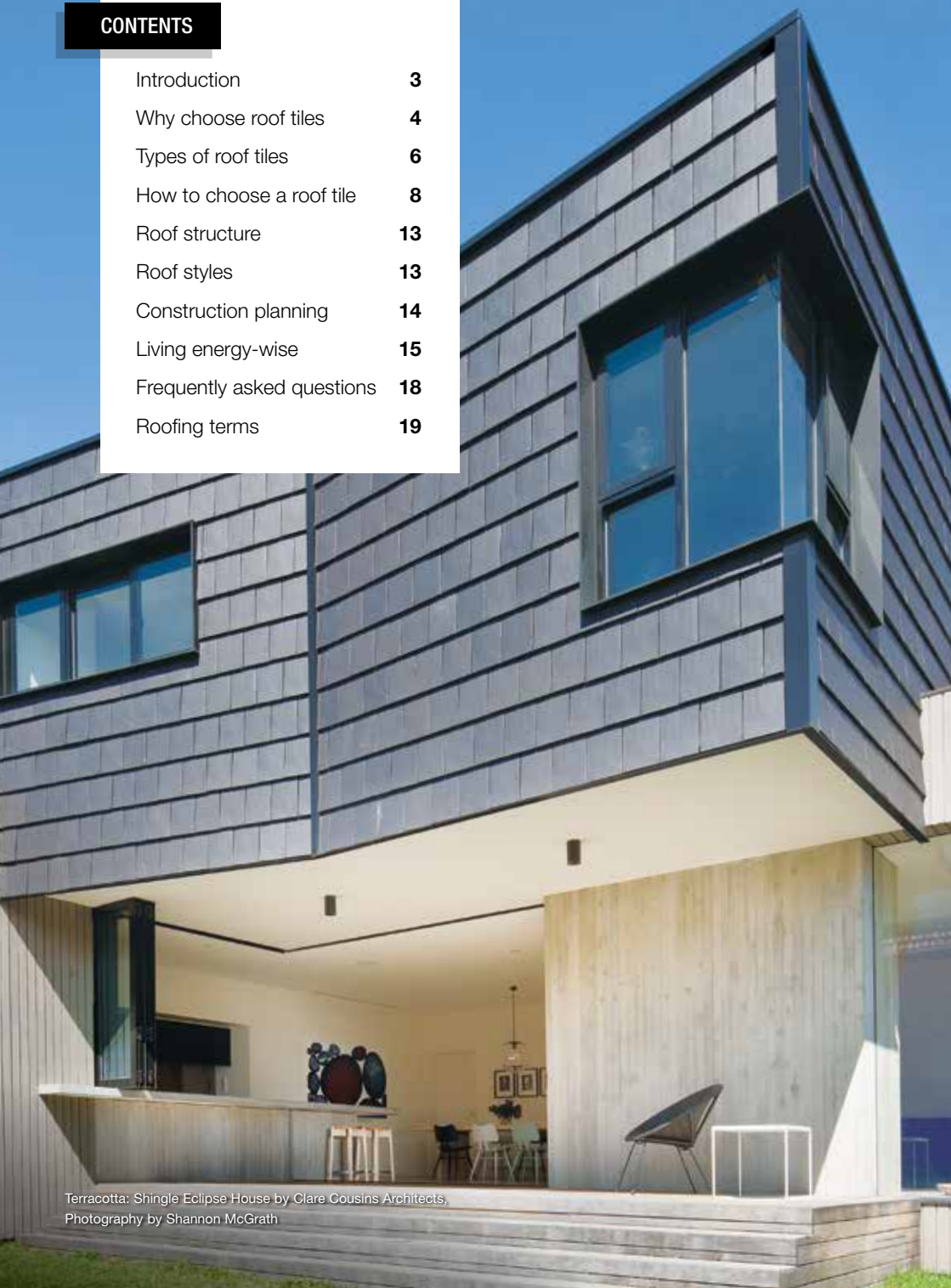



INTRODUCTION

Your home is one of your most important assets. The roof protects and defines your home. It's also the single largest surface area of a house, making it one of the most important architectural features of the structure.

If you're building your dream home from scratch, extending, renovating or just re-roofing, it's important to choose carefully. Your roof should be strong and resilient while perfectly complementing your home's architectural style.

This guide is designed to help you make the right choice. It introduces some basic roofing information and takes the guess work out of making decisions about your roof.

WHY CHOOSE ROOF TILES?

Roof tiles offer unsurpassed style, versatility and performance.



Concrete: Vogue Gunmetal

DESIGN
FLEXIBILITY

COLOUR
RETENTION (TERRACOTTA)

LONG
LASTING

LOW-
MAINTENANCE

SALT-SAFE AND
FROST-RESISTANT

ACOUSTIC
PERFORMANCE

FIRE
RESISTANCE

THERMAL
PERFORMANCE

WIND
RESISTANCE

RAIN WATER
RETENTION

The extensive range and unique design of individual tile profiles mean enhanced flexibility in roof design to complement a wide range of architectural styles and specifications. Terracotta and concrete roof tiles each offer a different aesthetic and surface finish.

Terracotta tiles are crafted from prepared natural clays that are kiln-fired to temperatures of 1100°C. This means the colour is locked in, so terracotta tiles retain their original appearance as they age. Concrete tiles will weather with age to a matt finish and will lose some colour over time. This colour loss does not affect the tile's performance.

With a **50**-year performance guarantee for terracotta tiles and **20** years for concrete tiles, Boral roof tiles are built to last and withstand harsh climatic conditions and marine environments. Australian experiences indicate that the performance of our tiles will continue for even longer.

Once tiles are installed there is little maintenance required because they do not rust or corrode. Should a section of the roof ever be damaged, there is the added advantage of individual tile replacement. This is a cost-effective option compared with large steel sheets.

Concrete and terracotta tiles are salt-safe and frost-resistant, making them suitable for any location. Coastal homes can be more prone to salt attack, the process by which salt crystals break down the materials used in and around the home¹. All Boral tiles are exposure-grade and suitable for salt-exposed environments, including harsh marine areas.

The density of tiles helps reduce external sound, such as aircraft and road noise and, particularly, rain and hail. In fact, roof tiles have a sound reduction potential twice that of sheet steel roofing².

Terracotta and concrete roof tiles are made from non-combustible materials and can safely be used in bushfire prone areas, including the highest prone areas (BAL-FZ). When installed to the Australian Standards, they provide superior protection against radiant heat from bushfires.

Roof tiles can help you enjoy more comfortable living in summer and winter. The thermal mass of clay and concrete materials when used correctly can result in advantageous insulation properties, in addition to considerations such as sarking and overall solar design.

The weight of the roofing material itself impacts performance in high wind areas. The dead load of roof tiles reduces the impact of uplift pressures in comparison to lighter-weight materials such as steel sheeting³.

Boral roof tiles are made to Australian standards and are suitable for the collection of rain water.

1. "A technical guide: Salt attack and rising damp," David Young, 2008.

2. "Roof Acoustic Performance- Noise Attenuation," Max Granger, Roof Tile Association of Australia, 2013.

3. "The Properties of Roof Tiles," Roof Tile Association of Australia, 2013.

TYPES OF ROOF TILES

Boral has an extensive range of terracotta and concrete roof tiles manufactured in Australia for Australian conditions and we offer roofing solutions to suit almost any style of home.

TERRACOTTA

Meaning 'baked earth' in Italian, terracotta is a natural clay product that has been used throughout the ages for protection against the elements.

Boral terracotta tiles are manufactured using carefully-selected clays that are kiln-fired to temperatures of 1100°C, resulting in a strong yet lightweight roofing material of exceptional quality.

The outstanding colour performance is achieved through the firing process known as vitrification. Clay and glaze materials fired at high temperatures melt and fuse together resulting in a finished tile resistant to harsh UV exposure.



Although architectural styles and materials come and go, the roof tile has endured the test of time, remaining one of the most popular forms of roofing materials.

CONCRETE

Modern concrete tiles are made from sand and cement with a pigmented colour coat. This can replicate the appearance of a broad array of distinctive tile designs, while remaining relatively cost-effective.

Boral concrete tiles are manufactured using an extrusion process resulting in the utmost strength and density. After moulding and colouring we apply a sealant finish that protects against efflorescence, a salty white deposit that can form on masonry and concrete products.



HOW TO CHOOSE A ROOF TILE

Follow these five simple steps to choose the right Boral roof tile for your home:

STEP 1 MATERIAL

STEP 2 TILE PROFILE

STEP 3 COLOUR AND FINISH

STEP 4 ACCESSORIES

STEP 5 INSTALLATION



Terracotta: French Eclipse

STEP 1: MATERIAL

Your choice of material will come down to personal preference in shape, colour and finish. Both terracotta and concrete tiles are built to last, with a 50-year guarantee on terracotta tiles and a 20-year guarantee on concrete tiles. Some customers prefer the natural beauty of terracotta while others appreciate the versatility of concrete.

Terracotta and concrete tiles also differ in size and shape. This means there will be differences in the number of tiles per square metre, as well as in the system of aligning the tiles on the roof next to each other (called the bond).

Terracotta tiles are slightly smaller than concrete tiles. Depending on the complexity of the roof design, an average of 13 tiles are needed per square metre. They are designed to interlock at both the head and the sides and are laid in either a cross-bond or straight-bond pattern, depending on the profile.

Because concrete tiles are slightly larger, approximately 10 concrete tiles are needed per square metre. These tiles are designed to interlock at the sides only but can also be laid cross-bond or straight-bond.

Remember, all Boral roof tiles are salt-safe, frost-resistant and non-combustible, making them suitable for any location, including coastal areas and bushfire-prone areas.

cross-bond pattern straight-bond pattern

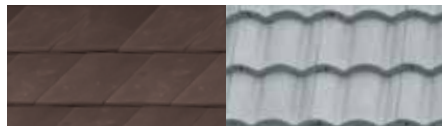

STEP 2: TILE PROFILE

The profile refers to a tile's shape and design at its cross-section. This can be either flat or shaped, with further design variations within these categories.

A key consideration when choosing a profile is the architectural style of the house as well as the pitch of your roof. In areas with a lot of rainfall, for example, you may want a steeper roof pitch so the rainwater will run off faster. The channels in shaped profile tiles also act as a natural watercourse for rain.

For a more streamlined contemporary look, try a flat profile, which delivers a flat, clean appearance.

TERRACOTTA TILES



CONCRETE TILES



HOW TO CHOOSE A ROOF TILE

STEP 2: CONTINUED

This table shows the minimum pitches for each profile & state.

MINIMUM ROOF PITCH* (DEGREES)						
PROFILE	MINIMUM PITCH WITHOUT SARKING			MINIMUM PITCH WITH SARKING		
TERRACOTTA						
Shingle	20			18		
French	20			15		
Swiss	20			15		
CONCRETE	NSW	VIC	SA	NSW	VIC	SA
Linea	n/a	20	20	20	20	18
Striata	-	20	20	-	20	18
Uno	-	n/a	-	-	20	-
Vogue	n/a	-	-	20	-	-
Capri	-	-	18	-	-	15
Contour**	20	20	-	15	15	-
Macquarie	20	20	-	15	15	-
Slimline	20	20	-	15	15	-

N/A means sarking is mandatory.
 * Maximum rafter length at the minimum pitch is 4.5 metres.** To be laid in a cross bond on pitches 20° and lower.

STEP 3: COLOUR AND FINISH

Colour can have a fundamental influence on the style, character and essence of your home. It's easy to feel overwhelmed by the sheer number of options available but by planning well in advance and following a few simple guidelines, you can create a look you will admire for years to come.

Here are five tips to remember when choosing a roof tile colour for your home:

1. A good place to start is by collecting reference material such as photos you've taken yourself or from magazines and brochures of inspiring colour schemes. Visiting builder display homes will also give you an abundance of colour ideas.
2. The architectural style of your home and its environment (including surrounding homes) is a major factor.
3. Primary considerations in selecting roof colour are the guttering and fascia finish of your home, as these are in closest proximity.
4. Visit a display centre to see the products in real life and how all the exterior colours work together. Make a shortlist of your selections and ask to take a sample home with you so you can think about it.
5. Trust your instincts and choose what's right for you, not your friends or family.

As a general rule, look for colours that together are either in harmony or contrast. Next are exterior walls, garage doors and window frames.

Boral offers a palette of warm, cool and neutral tones in both its terracotta and concrete ranges. Mix and match your roof tile with fascia, gutter and brick colours at: www.boralsampler.com.au



Finish There is a large assortment of colours available across the terracotta collection. These are applied in four different finishes: full glazed (in either high-gloss or matt); semi-glazed, for a traditional mottled appearance; or unglazed for the look of natural clay.

There are two finish options in the concrete collection: Colour-On and Colour-Through. As the name suggests, Colour-On is a coating applied to the surface of each wet extruded tile, whereas in our Colour-Through tiles, the oxides are blended through the concrete mix for a smooth surface finish and longer-lasting colour. We apply to both options a tinted acrylic sealant that protects the tile during the initial curing stage.



Unglazed



Semi-glazed



Full glazed - gloss

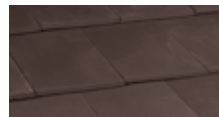

Full glazed - matt

HOW TO CHOOSE A ROOF TILE

STEP 4: ACCESSORIES

Finally, it's time to accessorise your roof and, when it comes to roofing, it's not merely a case of optional extras. Some accessories, such as sarking, have become essential to enhance functional performance. Others are designed for their aesthetic qualities and, like everything else in your home, the right accompaniments can turn a generic feature into a standout one.

Boral's roofing accessories include:

Sarking: This reflective foil insulation is recommended for all tiled roofs to enhance energy efficiency and weather-proofing (see page 17 for more details). It must be installed at the time of building.

Accent Ridging for terracotta tiles: Accent Ridging is a low-line ridge system to enhance terracotta tiles. Whether flat or shaped in tile profile, Accent Ridging seamlessly aligns ridge capping end-to-end in one smooth line without steps.



Other accessories Depending on the style of your house and design of the roof, Boral offers other ways to finish off ridges and apexes as well as some more traditional crests and finials.

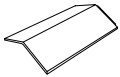

Accent Ridge

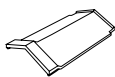

Vee Ridge



Ridge Crest



Gable Finial



3 way Apex



Spoon Apex

STEP 5: INSTALLATION

Getting a great roof is also dependent on good installation from a qualified installer. To be sure your roof is installed to Boral specifications we recommend our own supply-and-fix service, or an established installer from the Boral installer network (in New South Wales and Victoria only).

Boral's supply-and-fix service for new homes means Boral organises all the materials required as well as the installation.

We can prepare an obligation-free quote, to services such as pre-handover roof inspections. For renovations, extensions and re-roofing, call us for a referral to a Boral installer near you.

Boral's supply-and-fix service offers:

- Sales support
- Boral site supervisors
- Work Cover compliancy
- Technical support
- Fixing and product warranty
- Product estimates and quotations
- Trade qualified roof tilers
- Guard rail installation
- Pre-handover roof inspections available

Boral's supply-and-fix service, available in New South Wales, Victoria and South Australia.

ROOF STRUCTURE

The design of a roof is expressed through two key elements: the supporting structure; and its covering material (or cladding).

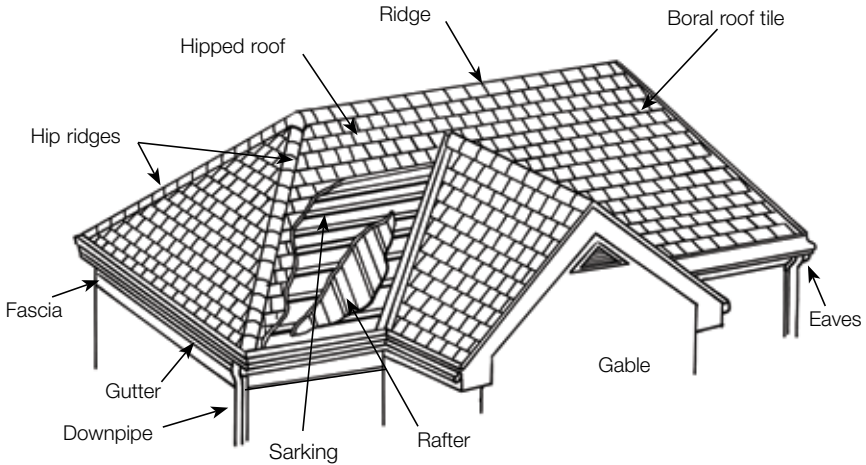

ROOF STYLES

There are seven basic roof designs, often used in combination on the one house.

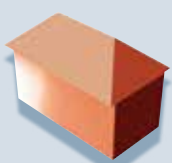

Hipped

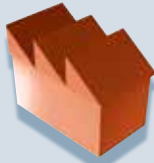

Sawtooth



Mansard



Gable



Dutch Gable



Skillion

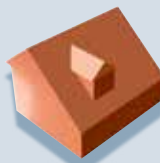

Dormer

CONSTRUCTION PLANNING

Getting the best roof in terms of both looks and performance requires careful consideration and planning. Here are some tips:

Before anything else, find out from your local council what regulations govern alterations or additions in the area. There may be restrictions such as height limits that you need to be aware of from the outset or possibly certain colour tones that are mandatory. In the face of height restrictions, consider a flatter roof pitch to maximise internal height and provide a more spacious living environment.

If you're planning major work, an architect or building designer can turn your dream into reality. Personal referrals can be ideal but it's good to do your own research to find someone who is best suited to your exact needs.

Check your state's energy efficiency requirements and look at how your project can work to reduce energy and water consumption. Energy-efficient living is not an add-on, but is easy to achieve by integrating some simple principles now.

Manufacturers of roof materials will specify the most suitable pitch for their products. As a general rule, the roof pitch will govern the length of the framework rafters, so decide on these two components at the design stage.

Getting a good roof is also dependent on finding a qualified contractor along with selecting the right materials. Consider a builder who is familiar with your area and who may have had experience dealing with the local council. For registered builders, enquire with the Housing Association of Australia or Master Builder's Association.

Visit a Boral Selection Centre and discuss the various details of your roof construction while it's still at the design stage. Don't forget to test www.boralsampler.com.au to help visualise what your exterior scheme might look like.





LIVING ENERGY WISE

An energy-wise home uses the best combination of sustainable building considerations such as site orientation, wall and ceiling insulation, ventilation, and materials to reduce overall energy consumption.

The Nationwide House Energy Rating Schemes (NatHERS) uses computer simulations to assess the potential thermal comfort of a home, delivering an energy rating. The aim is to integrate sustainability into design development from the outset. The position of a house relative to the sun will drive considerations to best utilise its natural energy for cool summers and warm winters indoors. This is called 'passive solar design'.

The principles are surprisingly simple, but the end result is a more comfortable home naturally, year-round, benefiting both the environment and your wallet.

LIVING ENERGY WISE: ENERGY EFFICIENT ROOF SYSTEMS

THERMAL PERFORMANCE

Concrete: Contour Gunmetal

Thermal mass can contribute to a roof's overall performance.

Thermal mass is the ability of a material to retain heat and is an important aspect in most Australian climates where low minimum temperatures and high maximum temperatures make it desirable to create a more comfortable middle ground.

High thermal mass materials such as clay and concrete, when used correctly, are able to even out the temperature by slowly absorbing heat energy during the day and slowly releasing it through the night. Another consideration to performance is the proportion of solar energy the roof takes in and transmits through the roof space, due to the colour of the roof. This is known as solar absorptance. A lower solar absorptance, generally lighter colours, can keep the roof space and dwelling cooler on a hot day. The amount not absorbed is reflected off the roofing material (solar reflectance) back into the atmosphere.

Colours, however, have a limited impact on thermal performance when elements such as sarking, insulation and ventilation are incorporated.

SHADING

Features like extended eaves are popular solar design attributes that provide desirable shading in summer while still letting in the low winter sun.



VENTILATION

Cross-ventilation, with at least two openings in each room, allows a breeze to circulate for a cooler home and is an important aspect in the passive design of a home. Ventilation is also of high importance in the roof space providing a buffer area between the inside and outside, helping regulate air flow all year round. Particularly in warmer climates, it helps to minimise radiant heat building up in the day while allowing it to escape in the evening.

WATER COLLECTION

The ability to efficiently collect rain water for tanks is directly affected by the roof's span. It is also important to ensure the guttering and downpipe system is of adequate size. Tiled roofs of greater pitch will more efficiently deliver rainwater to this system thanks to the pull of gravity.

SARKING

Insulating walls and ceilings is one of the best ways to efficiently regulate temperature. Equally important is the reflective, non-flammable foil insulation called sarking.

It is a thin blue membrane that sits between the rafters and roof tile battens and is recommended for all tiled roofs to maximise the energy efficiency of your home and to ensure your roof remains water tight.



Aside from the tiles themselves, sarking delivers front line protection against the elements and has two primary purposes.

One

The reflective foil finish minimises heat transmission into the roof space, which can dramatically reduce the temperature in the roof on hot days, allowing conventional insulation like fibreglass batts to work more effectively. In winter it works in the reverse by reducing heat loss through the roof.

Two

Sarking is also a secondary barrier to water entry, providing an extra level of security against unpredictable storms.

Sarking is **mandatory** in bush fire zones, in high wind areas and when roof pitches are less than 18° to protect against wind driven rain.

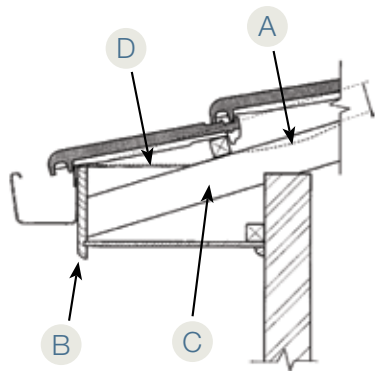

- A. Sarking
- B. Fascia Board
- C. Rafter
- D. Anti-ponding Board

FREQUENTLY ASKED QUESTIONS

How do I best maintain my roof? Maintaining tiles requires minimal effort, however maintenance should still be done regularly. To reduce the risk of leaks:

- Clean out blocked gutters, valleys and downpipes
- Re-bed or re-point hip and ridge capping if the cement mortar bedding is cracked or broken
- Replace any individual cracked or broken tiles and make sure all tiles are positioned correctly
- Remove any build-up of dirt or debris which may block the drainage channels under the 'side laps' on individual tiles
- Correct any blocked, damaged or displaced flashings

Boral always recommends contacting a roof maintenance specialist who can safely inspect, clean or fix your roof.

Can I respray tiled roofs? Depending on the material and method used it is completely acceptable to respray concrete roof tiles. However, never respray terracotta as it would interfere with the natural quality of the clay and, over time, the coating will peel away from the glazed surface.

Why is concrete not as colour-fast as terracotta? Concrete tiles are not glazed so, like all exterior building materials, they are subject to UV radiation and atmospheric pollutants. As a result they will weather with age to a matt finish and will lose some colour over time. Terracotta tiles are kiln-fired with a vitreous coating that makes these tiles resistant to harsh UV exposure.

What is lichen? Lichen or moss can start to grow on tiles after long periods but does not in any way indicate deterioration or affect the performance of tiles. It can be easily removed with a high pressure cleaner by a professional cleaning contractor.

What are the white streaks apparent on some roofs? Sometimes the natural mineral salts in concrete can migrate to the surface in the form of whitish grey discolouration called efflorescence. This is not harmful, has no impact on the performance of the tile and will weather away over time.

How long will it take to install my roof? The average roof is around 210 square metres, which takes approximately two days to install and fix, assuming weather is not an interfering factor. Allow another day for each additional 100 square metres.

I live near the water, is my warranty still valid? The Boral roof tile guarantee is valid no matter where you build your home and not dependent on how close or far you are from the coast. All Boral roof tiles are salt-safe and can be used even in severe marine environments.

What is NatHERS or BERS?

The Nationwide Housing Energy Rating Scheme (NatHERS) and Building Energy Rating Scheme (BERS) are energy simulation computer programs that provide thermal ratings for homes. They are employed during the design stage to enhance the energy efficiency of a new development.

ROOFING TERMS

APEX	The intersection of all ascending hips where they meet either a ridge or another ascending hip.
BATTENS	Selected-sized timber fixed parallel to the eave line on which tiles are fixed.
BOND	The system of aligning tiles on the roof in relationship to each other. With straight-bond, the sides of tiles form straight lines from bottom to top. With staggered-, broken- or cross-bond, tiles in each alternate course overlap, by half, the tiles above and below them.
EAVES	The lowest overhanging part of a sloping roof, which projects beyond the external wall.
FASCIA BOARD	A wide board set vertically on edge, fixed to the rafter ends or wall plate or wall. It carries the gutter.
GABLE/ GABLE END	The triangular part of the end wall of a building with a sloping roof.
HIP	The edge formed by the meeting of two pitched roof surfaces.
HIP CAPPING	Or ridging. A shaped capping for hips to prevent water penetration.
PARAPET WALL	Usually a brick or timber structure rising above the roof line.
PITCH	The ratio of the height to the span of a roof, or its angle of inclination to the horizontal.
POINTING	A mixture of clean sand, cement and oxide colouring or a pre-mixed flexible material used for the completion of joints between ridge or hips and with roof tiles or tiles at gable ends.
RAFTER	A sloping timber extending from the eave to the ridge of a roof.
RIDGE	The apex of a roof, usually a horizontal line.
VALLEY	The intersection between two sloping surfaces of a roof, towards which water flows, the opposite of a hip.

Call us on 1300 134 002

Visit us at www.boral.com.au/rooftileguide

Visit a display centre



New South Wales

Albion Park Rail - 49 Durgadin Drive, Albion Park Rail, 2527

Albury - Corner Ebden & Townsend Sreet, Albury, 2640

Badgerys Creek - 235 Martin Road, Badgerys Creek, 2555

Emu Plains - MacKellar Street, Emu Plains, 2750

Wyee - 288 Tooheys Road, Bushells Ridge, 2259

Victoria

Caroline Springs - 1037 Western Highway, Caroline Springs, 3023

Geelong West - 38 Pakington Street, Geelong West, 3218

Scoresby - 191 George Street, Wantirna South, 3152

Springvale - 66-78 Tootal Road, Dingley Village, 3172

Thomastown - 2 Trawalla Avenue, Thomastown, 3074

South Australia

Pooraka - 1161 Main North Road, Pooraka, 5095

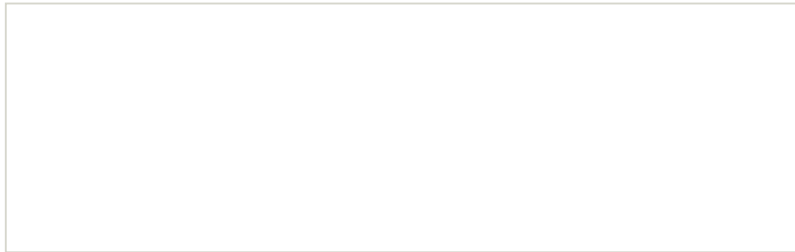

Important Information: Product information contained in this leaflet is correct at the time of printing however is subject to change without notice. Some photos featured in this brochure are artist's impressions of how Boral roof tiles will look on a roof. Some images are computer generated. Please ensure you view a tile display before making a final decision. Colours shown are indicative only and should not be used for final selection. Colours are subject to change without notice. Check print date prior to product selection. Roof tile colours may vary in shades throughout the manufacturing process therefore it is important that roof tiles are blended consistently across the roof. At Boral Roofing, all tiles are manufactured to the requirements of Australian Standard 2049 Roof tiles. Please ask for a copy of the Boral Roofing guarantee before making your purchase. During transportation and installation small blemishes such as scuffing and chip marks may occur. These are not considered a production fault and will not detract from the performance of the roof tile. © Copyright Boral Roofing – all rights reserved 2014. Boral, the Boral logo, boral.com.au, are trade marks or registered trade marks of Boral Limited or Boral Montoro Pty Ltd trading as Boral Roofing or Boral Roof Tiles in Australia, other countries, or both. If these and other Boral trade marked terms are marked on their first occurrence in this information with a trade mark symbol (® or ™), these symbols indicate Australian registered or common law trade marks owned by Boral at the time this information was published. Such trade marks may also be registered or common law trade marks in other countries. Other product, company or service names may be trade marks or service marks of others. Boral Roofing ABN 34 002 944 694. Correct as at August 2014.